

C series

CD series

Owner's Guide

# SOLAR CHARGE CONTROLLER



C-CD-202Z30\*101125

Tips:the picture and function description just for reference,and we reserve the right to change it and have no notice.



ISO9001:2000 ROHS (SON) (EB) CE

Refer to the sticker on box for detail model !

# Content

1.Introduction .....	1
2.Features .....	1
3.Model Explanation .....	1
4. Installation and Connection .....	2-4
5.Grounding the Solar System .....	5
6.Starting up the Controller .....	5-6
7.Display and Functions .....	6-7
8.Settings .....	8
9.Error Description .....	9
10.Recommended Safety and Application Procedures .....	10
11.Liability Exclusion .....	10
12.Technical Data .....	11

Thank you for placing your trust in us.

Please read these instructions carefully before starting to use the solar charge controller.

## 1 Introduction :

There is C and CD series solar charge controller.

The C series charge controller is designed specially for use in solar systems where the DC output for DC load is not required. It ideally suited for applications on yachts and in caravans.

The CD series solar charge controller is a perfect solution for cost-sensitive PV systems. It has DC output for DC load. It is one of the world's best-selling small solar charge controller.

## 2 Features :

- High Efficiency charging process

Temperature compensation, three stage PWM series charging method, Lead acid battery or Gel battery used.

- Improved system indicators.

Four LEDs indicates the PV , battery ,loads status and Fault functions.

- Complete electronic protection

Fully protected against reverse polarity, short circuit, over current, over voltage and reverse current flow at any of controller terminals.

- Easy to connect

Large and rugged terminal block with anti-corrosive screws.

- Common positive allows grounding.
- Automatic temperature Compensation.
- Automatic reset.
- Easy to mount on Wall or rail.
- Blocking of the return Current .
- Large terminals (up to 16mm<sup>2</sup> wire size).
- Type of use selection (charge Verification or Voltage Verification)

## 3 Model Explanation

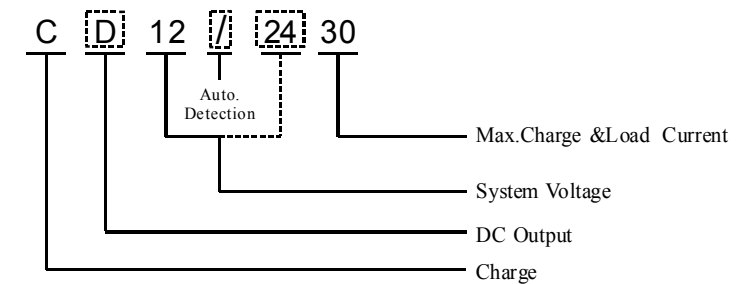

## 4. Installation and Connection

The controller is intended for indoor use only. Protect it from direct sunlight and place it in a dry environment. Never install it in humid rooms (like bathrooms).

The controller measures the ambient temperature to determine the charging voltage. Controller and battery must be installed in the same room.

The controller warms up during operation, and should therefore be installed on a nonflammable surface only.

### 4.1 Mounting

Note : Connect the controller by following the steps described below to avoid installation errors.

#### 4.1.1. Screw mounting

Mount the controller on the wall with screws that fit to the wall material. Use screws with 3.5mm shaft and max .8 mm head diameter, no counter sunk. (As below picture )

Note: Mind that the screws have carry also the force applied by the wiring. Make sure that the ventilator slits on the sides are unobstructed.



#### 4.1.2.DIN Rail Mounting

Push the rail - clip outside then mount it on a standard 35mm DIN rail.Push the rail - clip inside to fasten the controller onto the DIN rail.( As below pictures )

Note: the thickness of DIN rail should not more than 1mm ,suggest to choose the 0.8mm type.

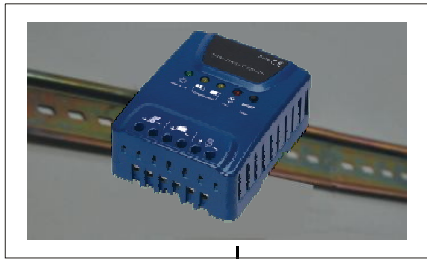

Push-out

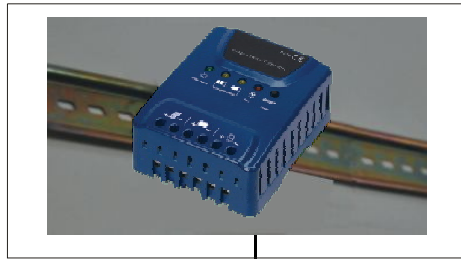

Push - in

#### 4.2 Battery and Controller Connecting

Please connect the controllers according this instruction!

Connect the wires leading to the battery with correct polarity.To avoid any voltage on the wires,first connect the controller , then the battery.Mind the recommended wire length (min 30cm to max approx. 100cm)and the wire size :



- 20A:min 6mm<sup>2</sup>
- 25A:min 6mm<sup>2</sup>
- 30A:min 8mm<sup>2</sup>

Warning : If the battery is connected with reverse polarity, the load terminals will also have the wrong polarity.Never connect loads during this conditions!

#### 4.3 Solar array and Controller Connecting

Please note that the solar panels total power should no more than the controller's rate power (voltage\*Amper (V\*A))!

Connect the wires leading to the solar array with correct polarity.To avoid any voltage on the wires ,first connect the controller , then the solar array.Mind the recommend ed wire size:

- 20A:min 6mm<sup>2</sup>
- 25A:min 6mm<sup>2</sup>
- 30A:min 8mm<sup>2</sup>

Attentions :

- Place positive and negative wire closeto each other to minimize electromagnetic effects.
- Solar panel provide voltage as soon as exposed to sunlight. Mind the solar panel manufacturer's recommendations in any case .



#### 4.4 Load and the Controller Connecting (CD Series only)

Connect the wires leading to the loads with correct polarity.To avoid any voltage on the wires, first connect the wire to load,then to the controller. Mind the the recommended wire size:

- 20A:min 6mm<sup>2</sup>
- 25A:min 6mm<sup>2</sup>
- 30A:min 8mm<sup>2</sup>

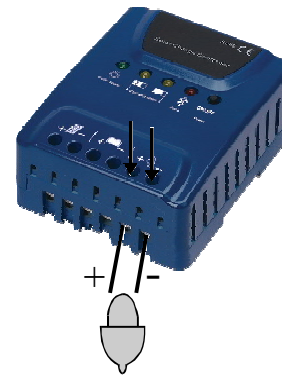

## 5. Grounding the Solar System

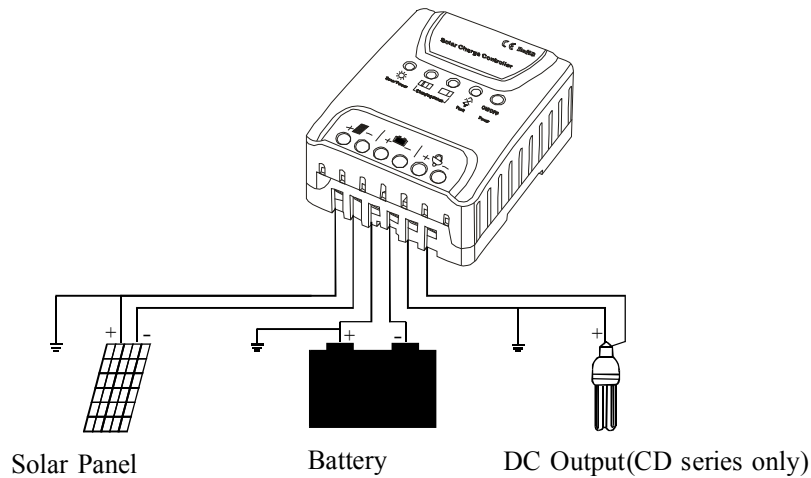

Be aware that the positive terminals of the controller are connected internally and therefore have the same electrical potential. If any grounding is required, always do this on the positive wires.

Note : If the device is used in a vehicle which has the battery negative on the chassis, loads connected to the regulator must not have an electric connection to the car body. Otherwise the Low

## 6. Starting up the Controller

### Self Test

The charge controller starts a self test when it is properly connected to the battery and solar panel. After which the display resets to normal operation.

### System Voltage

The controller adjusts itself automatically to 12V or 24V system voltage. As soon as the voltage at the time of start-up exceeds 18V, the controller implies a 24V system. If the battery voltage is not within the normal operation range (ca. 12 to 15.5V to ca. 24V to 31V) at start-up, a status display according to the section ERROR DESCRIPTION occurs.

## Battery Type

The controller is preset to operate with lead acid batteries with liquid electrolyte. If you intend to use a lead-acid battery with solid electrolyte ( "gel" type or "fleece" type ) you can adjust the charging characteristics ( see "settings" ). The equalization charge is deactivated then. In case of any doubts consult your dealer.

## 7. Display and Functions

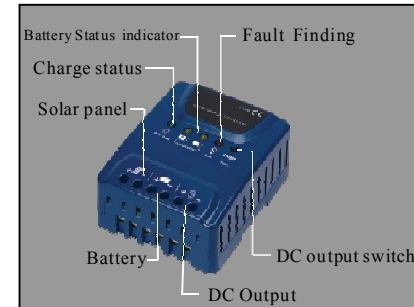

CD series

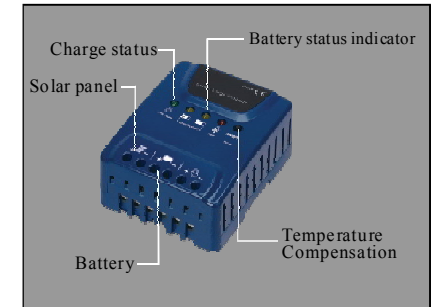

C series

### 7.1 Charge Status



Battery on charging (LED on)



Battery not in charging (LED off)

### 7.2 Battery Status Indicator

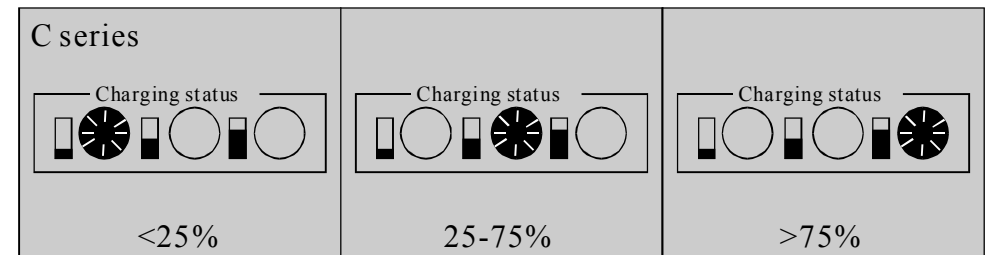

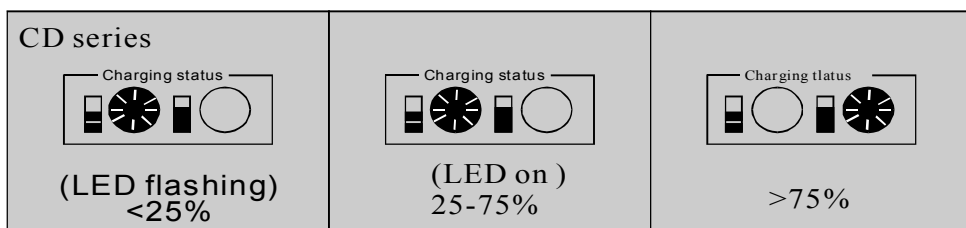

C series : 3 LEDs show the state of the battery s charge  
 First LED on : battery capacity <25%  
 Second LED on: battery capacity between 25% and 75%  
 Third LED on : battery capacity >75%

CD series: 2 LEDs show the state of the battery s charge  
 First LED flashing : battery capacity < 25%  
 First LED on : battery capacity between 25% and 75%  
 Second LED on : battery capacity >75%

### 7.3 Fault Finding

Fault LED flashes when there is an open circuit , or if there is an overload or short circuit.

### 7.4 DC Output Switch( CD Series only )

This switch turns the DC output on and off.

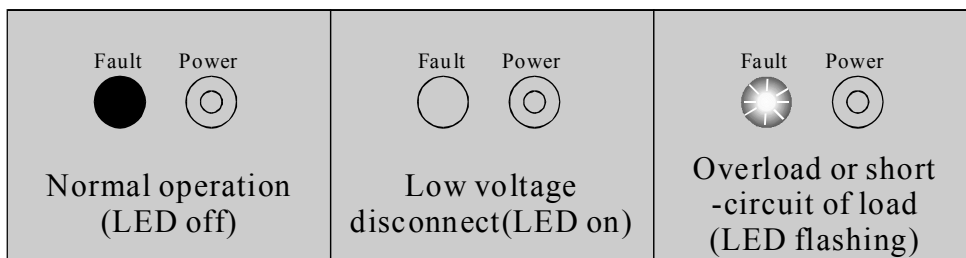

## 8.Settings

**WARNING:**The controller should not be open when it is plugged in or running!  
 Always disconnect the solar panels and the battery before opening the charge controller.

The controller can be configured for a particular purpose.

Charge the battery type ( Lead -acid and Gel)

To do this, open the lif of the controller by removing the screws on the back. !

When the controller is open,there is two jumper on the board. The controller is factory set with the jumper closed for GEL batteries.

To modify the settings, move the jumper on the connector pins.

To charge, turn the jumper which is covering both pins to cover only one

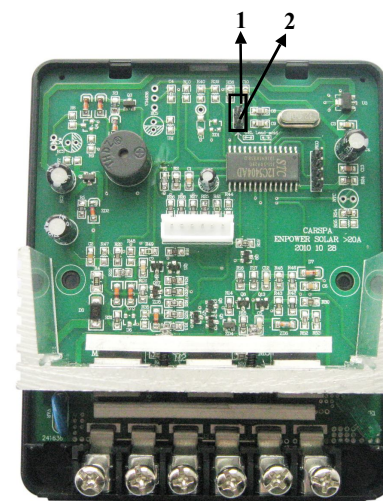

contact pin-see below.

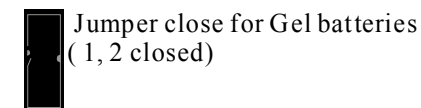

Jumper close for Gel batteries  
 ( 1, 2 closed)

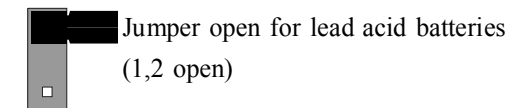

Jumper open for lead acid batteries  
 (1,2 open)

The controller is preset to open jumper from the factory

Jumper	Battery Type
Setting jumper open	Liquid electrolyte
Setting jumper close	GEL(VRLA battery)
Factory setting	Jumper open ( Liquid electrolyte)

After completing the setting, replace the cover and tighten it with the screws.

**9.Error Description**

Error	Display	Reason	Remedy
Loads are not supplied (CD series only)	LED is on (Red LED )	Battery is low	Load will reconnect as soon as battery is recharged.
	LED is flashing (Red LED )	Overcurrent/load	Switch off all loads.
		DC Loads Short Circuit	Remove the short circuit , Controller will switch on load automatically after 10 seconds
	LEDs are on	Battery voltage too high (>15.5/31.0V)	Check if other sources overcharge the battery. If not controller is damaged.
Battery wires or battery fuse damaged, battery has high resistance		Check battery wires fuses and battery.	
Battery is empty after a short time	LED is on (red LED)	Battery has low capacity	Change battery
Battery is not being charged during the day	LED is off (red LED)	Solar array faulty or wrong polarity	Remove faulty connection/ reverse polarity

**10.Recommended Safety and Application Procedures**

**Intended Use**

The charge controller is intended exclusively for use in photovoltaic systems with 12V or 24V normal voltage and in conjunction with vented or sealed (VRLA) lead acid batteries only.

The controller will become warm when working but no maintenance is required. Please use dry cloth to wipe off dust when needed. It is important that batteries are frequently fully charged (min once a month). Otherwise batteries might be damaged permanently. Also note that a DC loaded battery can only be charged full if the charging current is bigger than battery output.

**Product Application**

This charge controller is designed to be used with solar panels only. Designed voltage is 12V or 24V system (depending on the models) with lead acid battery or gel battery. Never short circuit batteries since they contain big (strong) power. We recommend connecting fuse on batteries (slow motion type according to the designed current). Batteries may release flammable gas. Please keep away from sparks, open fire. Store batteries in ventilated room.

Do not touch or short circuit connections/ terminals. Some wires or terminals may carry twice the voltage as batteries. To operate on batteries, make sure hands are dry and use isolation tools. Stand on dry ground. Keep children away from battery and controller.

**11.Liability Exclusion**

The manufacturer shall not be liable for damages, especially on the battery, caused by use other than as intended or as mentioned in this manual or if the recommendations of the battery manufacturer are neglected. The manufacturer shall not be liable if there has been service or repair carried out by any unauthorized person, misuse, incorrect installation and/ or bad system design. This product carries a warranty of two years from the date of original purchase. Warranty is limited to service or free replacement as determined by the manufacturer or your local distributor.

## 12. Technical Data

Model	C1220	C1225	C1230	CD1220	CD1225	CD1230	C2420	C2425	C2430	CD2420	CD2425	CD2430	C12/24-20	C12/24-25	C12/24-30	CD12/24-20	CD12/24-25	CD12/24-30
Nominal Voltage	12V						24V						12/24V Auto. Detection					
Battery Selection	Lead Battery with Liquid Electrolyte			Gel Battery			Lead Battery with Liquid Electrolyte			Gel Battery			Lead Battery with Liquid Electrolyte			Gel Battery		
Equalization Voltage	14.5V(25°C)			14.3V (25°C)			29V (25°C)			28.6V (25°C)			14.5V/29V (25°C)			14.3V 28.6V (25°C)		
Boost Voltage	14.8V (25°C)			14.4V (25°C)			29.6V (25°C)			28.8V (25°C)			14.8V/29.6V (25°C)			14.4V 28.8V (25°C)		
Float Voltage	13.7V (25°C)			13.6V (25°C)			27.4V (25°C)			27.2V (25°C)			13.7V/27.4V (25°C)			13.6V 27.2V (25°C)		
Low Voltage Disconnection	11V/22V Controlled by the Voltage																	
Low Reconnect Voltage	12.8V						25.6V						12.8V/25.6V					
Max. Charge Current	20A	25A	30A	20A	25A	30A	20A	25A	30A	20A	25A	30A	20A	25A	30A	20A	25A	30A
Max. Load Current				20A	25A	30A				20A	25A	30A				20A	25A	30A
Reverse Connection Protection for DC Output	Fuse 25A	Fuse 30A	Fuse 35A	Fuse 25A	Fuse 30A	Fuse 35A	Fuse 25A	Fuse 30A	Fuse 35A	Fuse 25A	Fuse 30A	Fuse 35A	Fuse 25A	Fuse 30A	Fuse 35A	Fuse 25A	Fuse 30A	Fuse 35A
Self-Consumption Current	4mA																	
Temperature Compensation	-4mV/cell * K																	
Operating Temperature Range	-40~50°C																	
Case Protection	IP22																	
Max. Wire Size	16mm <sup>2</sup> (AWG #6)																	
Dimension	11.5*9.2*4.8cm (L*W*H)																	
N.W.	243g			223g			243g			223g			243g			223g		

Specification prior to change without notice